

**EC7 Workshop, Pavia, April 2010**

# **Water pressures**

Brian Simpson, *Arup Geotechnics*

*with assistance from:*

Andrew Bond, Norbert Vogt, Adriaan Seters

# Three simple (????) problems

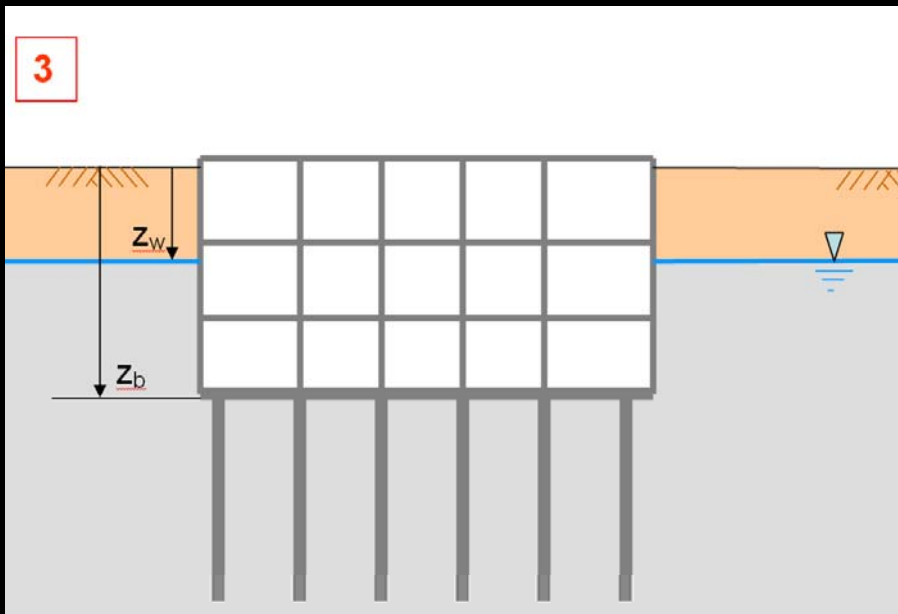
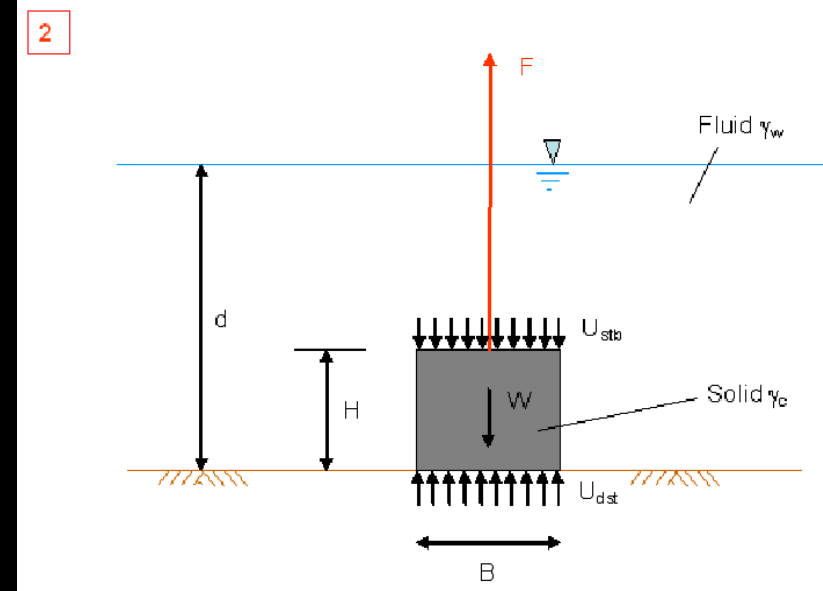
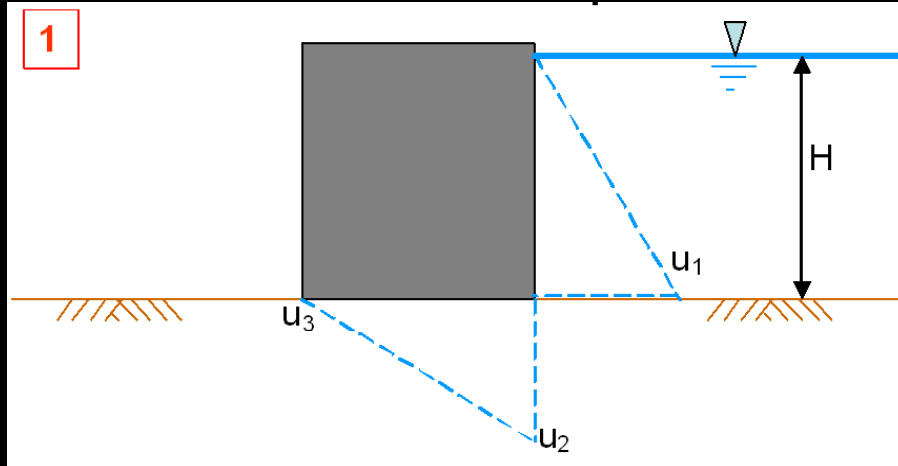

- Concentrating here on safety related to water pressure.
- Other issues complicate matters further:
  - DA's, materials, resistances, calculations models

# Extracts from EN1997-1

## 2.4.2 Actions

(9)P Actions in which ground- and free-water forces predominate shall be identified for special consideration with regard to deformations, fissuring, variable permeability and erosion.

NOTE Unfavourable (or destabilising) and favourable (or stabilising) permanent actions may in some situations be considered as coming from a single source. If they are considered so, a single partial factor may be applied to the sum of these actions or to the sum of their effects.

# Extracts from EN1997-1

## 2.4.6.1 Design values of actions

(1)P The design value of an action shall be determined in accordance with EN 1990:2002.

(2)P The design value of an action ( $F_d$ ) shall either be assessed directly or shall be derived from representative values using the following equation:

$$F_d = \gamma_f \cdot F_{rep} \quad (2.1a)$$

with

$$F_{rep} = \psi \cdot F_k \quad (2.1b)$$

...

(6)P When dealing with ground-water pressures for limit states with severe consequences (generally ultimate limit states), design values shall represent the most unfavourable values that could occur during the design lifetime of the structure. For limit states with less severe consequences (generally serviceability limit states), design values shall be the most unfavourable values which could occur in normal circumstances.

...

(8) Design values of ground-water pressures may be derived either by applying partial factors to characteristic water pressures or by applying a safety margin to the characteristic water level in accordance with 2.4.4(1)P and 2.4.5.3(1)P.

# Extracts from EN1997-1

## 2.4.7.3.2 Design effects of actions

(2) In some design situations, the application of partial factors to actions coming from or through the soil (such as earth or water pressures) could lead to design values, which are unreasonable or even physically impossible. In these situations, the factors may be applied directly to the effects of actions derived from representative values of the actions.

- DA2\* - or DA1\* ??

2

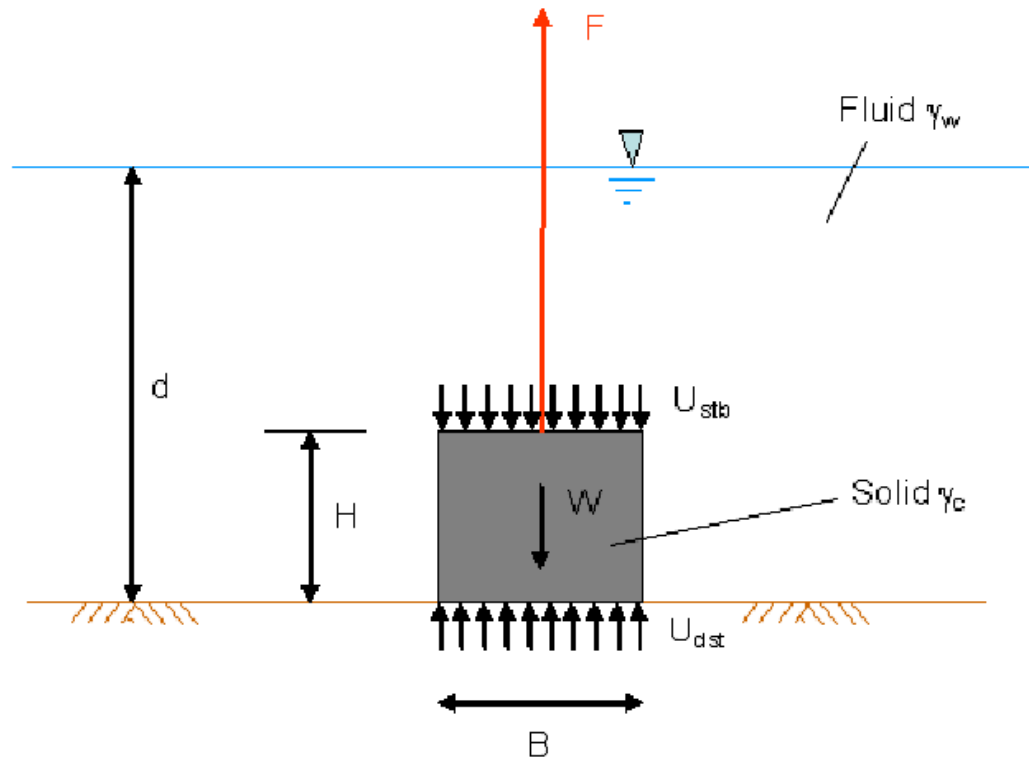

The figure shows an anchor block, for which  $W$  (total weight) is a favourable force and  $F$  is unfavourable.

$H$  = height of block

$B$  = breadth of block

$d$  = depth of water

$F$  = external force applied to block

$\gamma_c$  = weight density of block material (e.g. concrete)

$\gamma_w$  = weight density of water

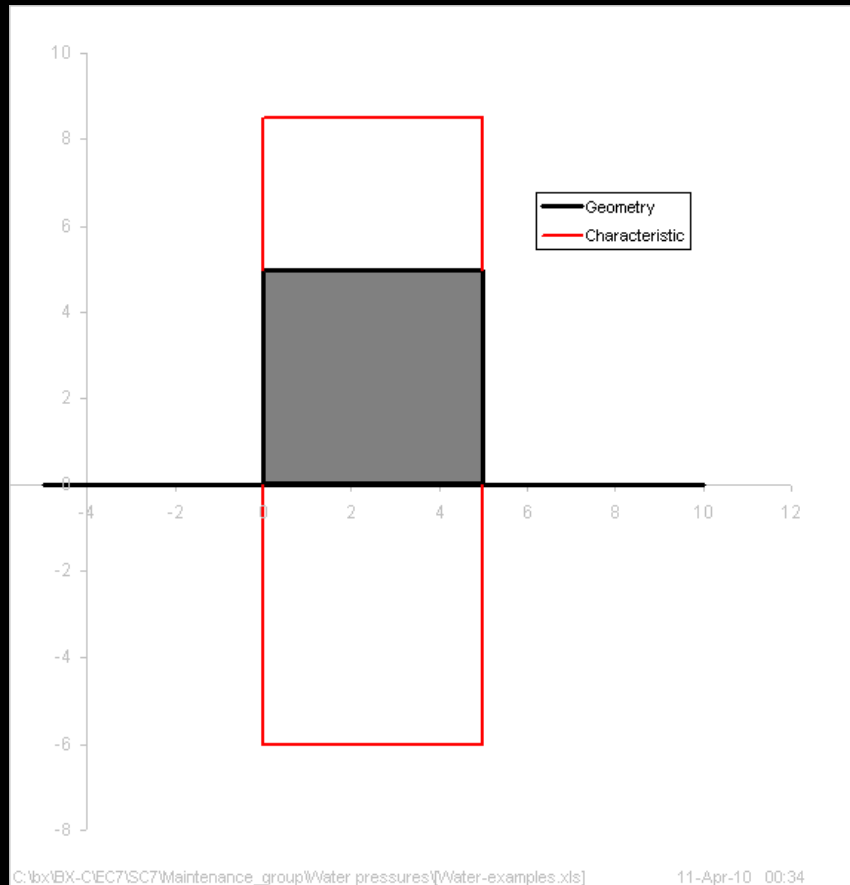

- Single source?
- Buoyant weight?

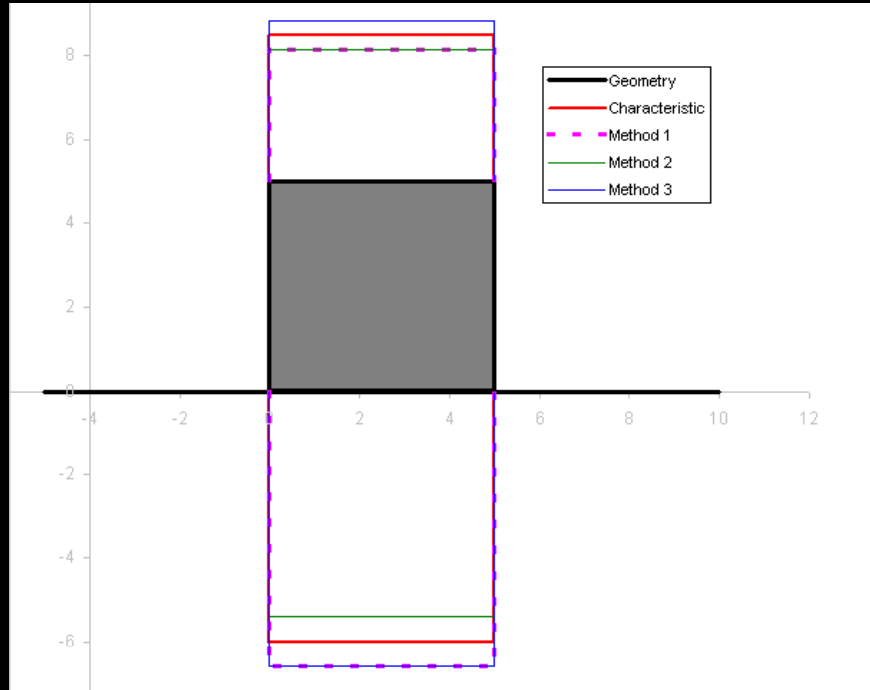

- Method 1 –  $\gamma_{dst} (>1)$  and  $\gamma_{stb} (<1)$ 
  - $W * \gamma_{G;stb} + U_{stb} * \gamma_{G;stb} \geq U_{dst} * \gamma_{G;dst} + F * \gamma_{Q;dst}$
- Method 2 –  $\gamma_{stb}$  and  $\gamma_{stb}$ 
  - $(W - \Delta U) * \gamma_{G;stb} \geq F * \gamma_{Q;dst}$  (buoyant weight method)
- Method 3 –  $\gamma_{dst}$  and  $\gamma_{dst}$ 
  - $W * \gamma_{G;stb} - \Delta U * \gamma_{G;dst} \geq F * \gamma_{Q;dst}$
  - relative water pressure method - “single source”



Example 2: consequences for uplift

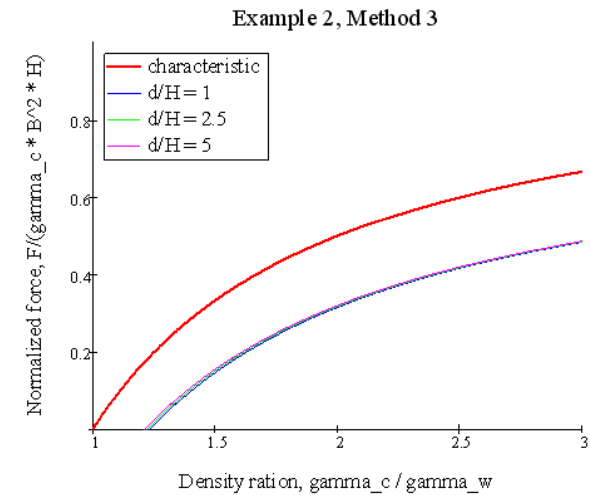
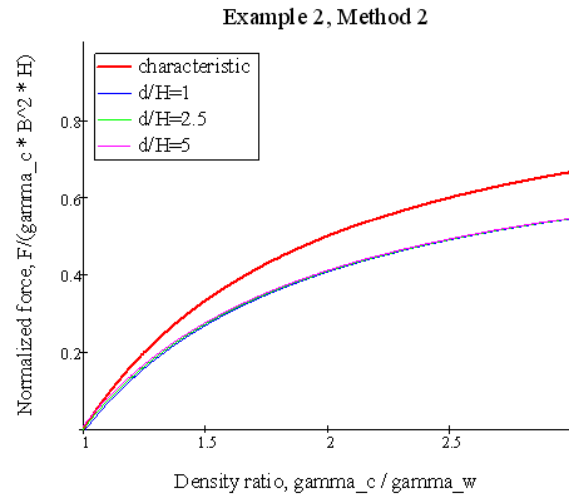
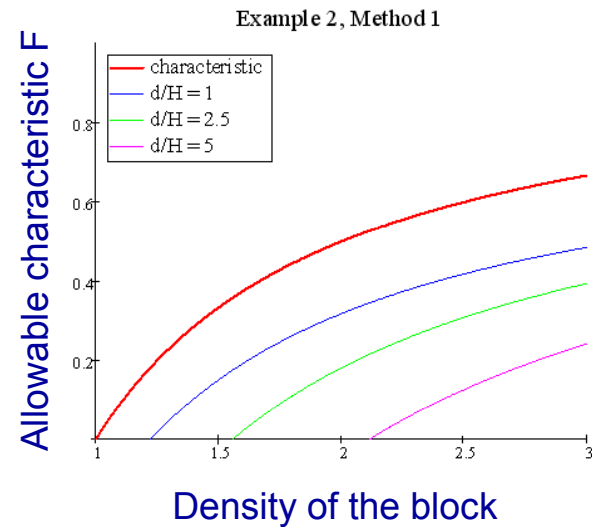

Observation: in Method 1, the acceptable force depends on the depth of water in which it sits

- Method 1 –  $\gamma_{dst}$  and  $\gamma_{stb}$ 
  - $W * \gamma_{G;stb} + U_{stb} * \gamma_{G;stb} \geq U_{dst} * \gamma_{G;dst} + F * \gamma_{Q;dst}$
- Method 2 –  $\gamma_{stb}$  and  $\gamma_{stb}$ 
  - $(W - \Delta U) * \gamma_{G;stb} \geq F * \gamma_{Q;dst}$  (buoyant weight method)
- Method 3 –  $\gamma_{dst}$  and  $\gamma_{dst}$ 
  - $W * \gamma_{G;stb} - \Delta U * \gamma_{G;dst} \geq F * \gamma_{Q;dst}$
  - relative water pressure method - “single source”

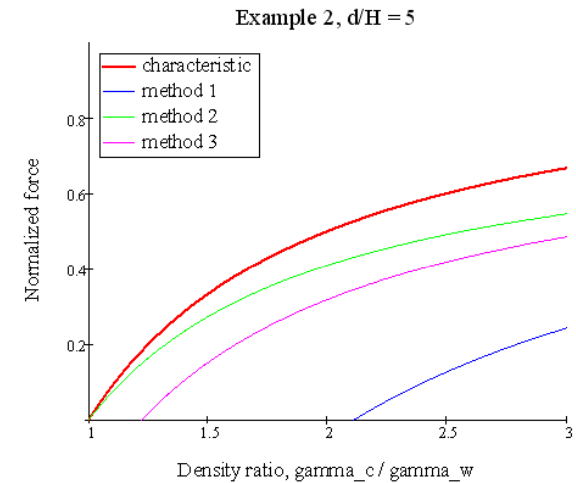
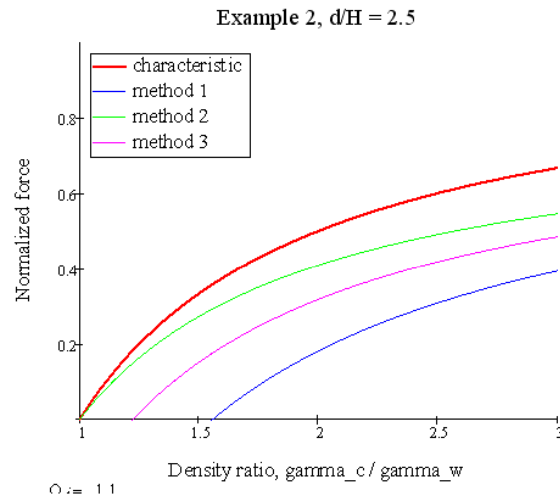
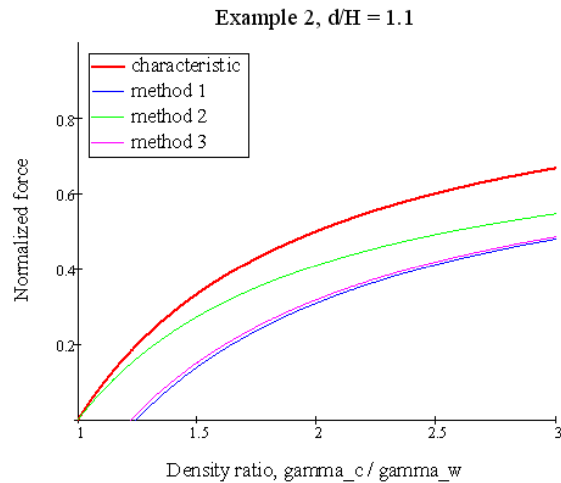

Observation: in Method 1, the acceptable force decreases as the depth of water increases **Factoring water pressures.**

Observation: in Method 2, the acceptable force approaches the characteristic force as the density of the block approaches that of water

Observation: Method 3 may be better, but still factoring the **density** of water.

- Method 1 –  $\gamma_{dst}$  and  $\gamma_{stb}$

- Method 2 –  $\gamma_{stb}$  and  $\gamma_{stb}$

- Method 3 –  $\gamma_{dst}$  and  $\gamma_{dst}$

- $W * \gamma_{G;stb} + U_{stb} * \gamma_{G;stb} \geq U_{dst} * \gamma_{G;dst} + F * \gamma_{Q;dst}$

- $(W - \Delta U) * \gamma_{G;stb} \geq F * \gamma_{Q;dst}$  (buoyant weight method)

- $W * \gamma_{G;stb} - \Delta U * \gamma_{G;dst} \geq F * \gamma_{Q;dst}$

- relative water pressure method - “single source”

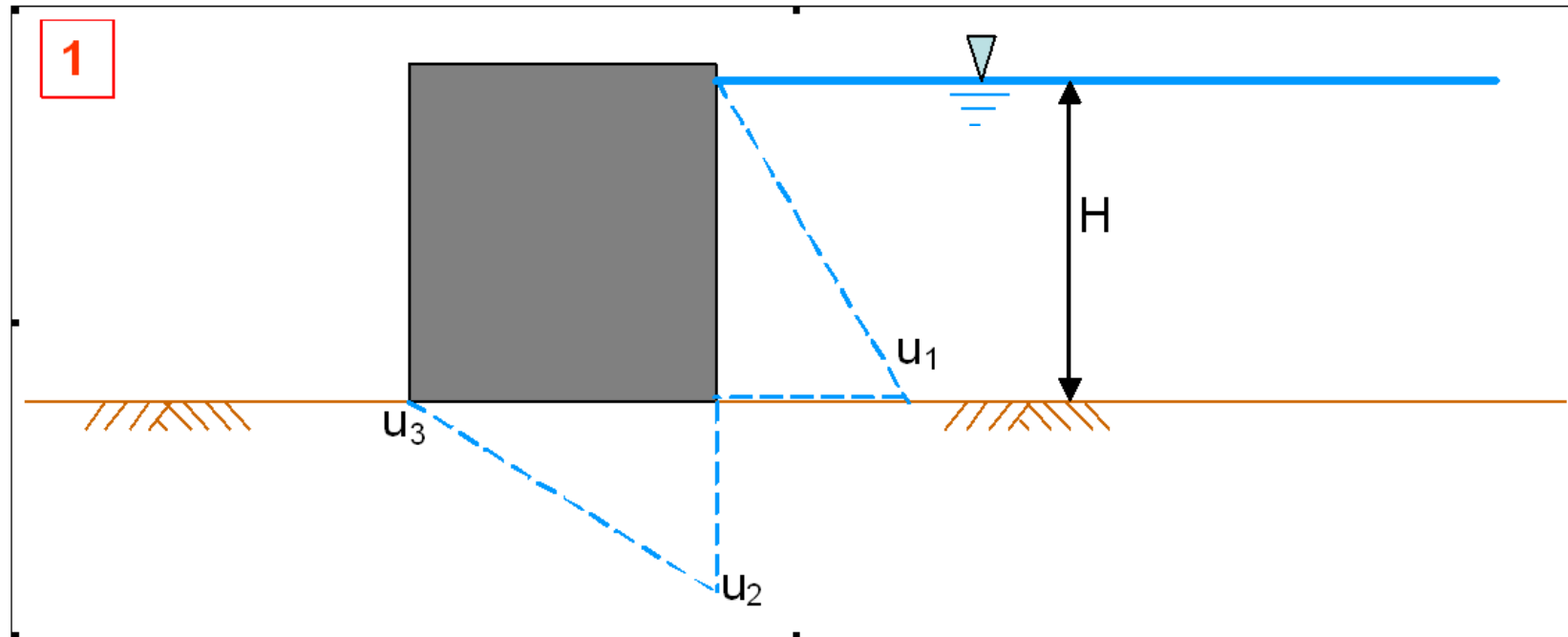

1 A wall or caisson supporting only water which can rise to the top of the caisson, at which point it overflows. The natural ground water level on the downstream side of the wall is at ground level. It has been determined that it is reasonable to assume a linear distribution of water pressure beneath the structure, as shown.

$H$  = height of block

$B$  = breadth of block

$\gamma_c$  = weight density of block material (e.g. concrete)

$\gamma_w$  = weight density of water

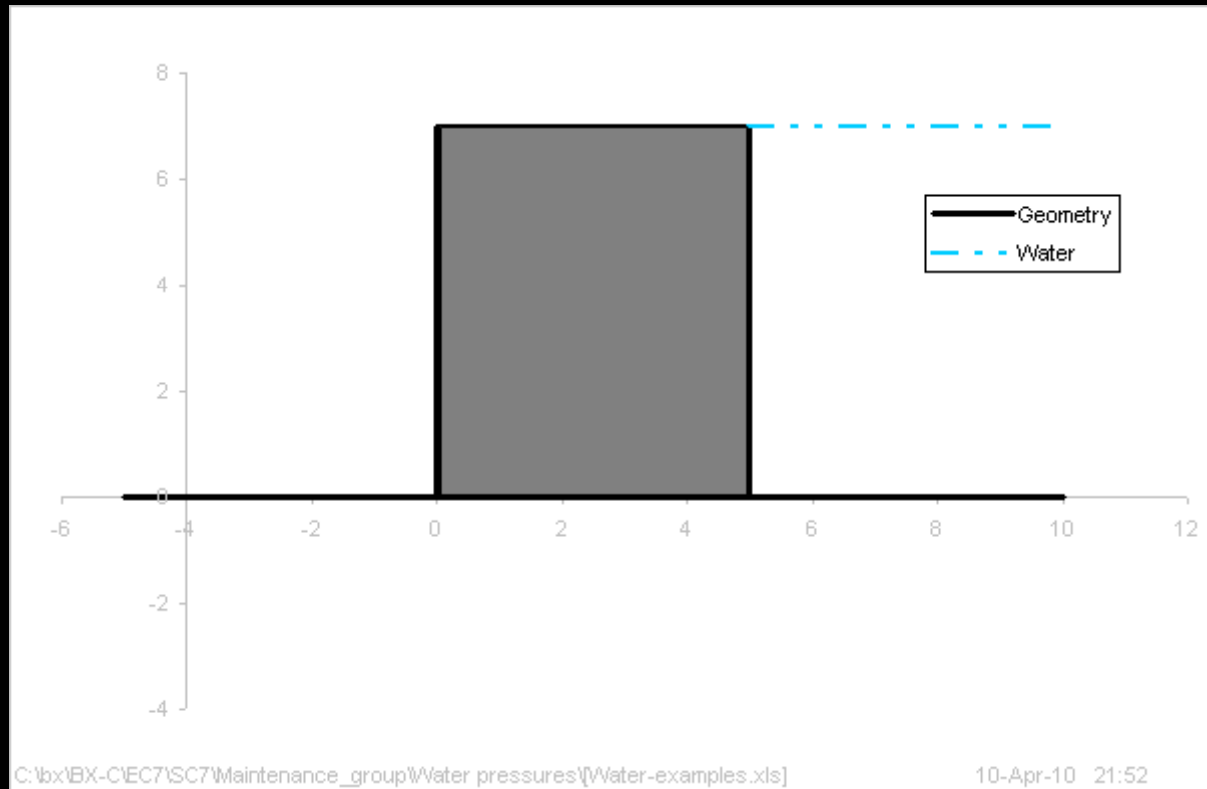

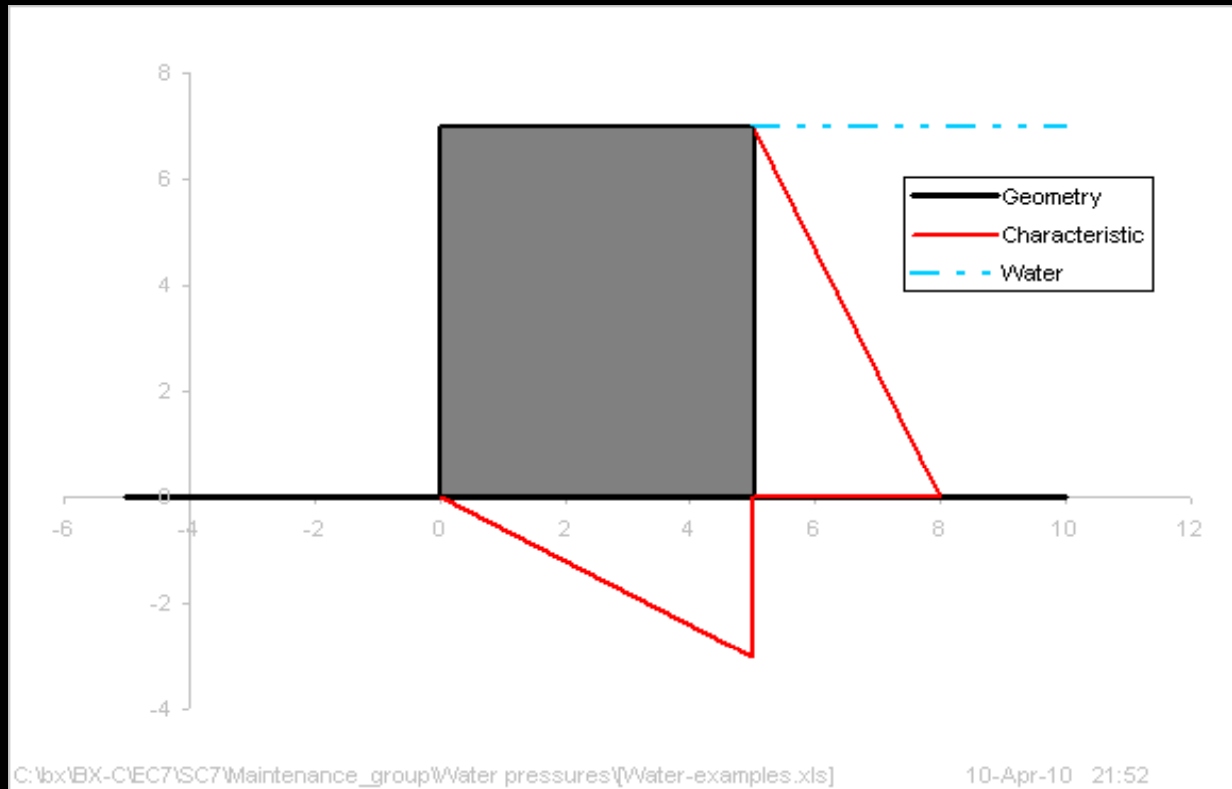

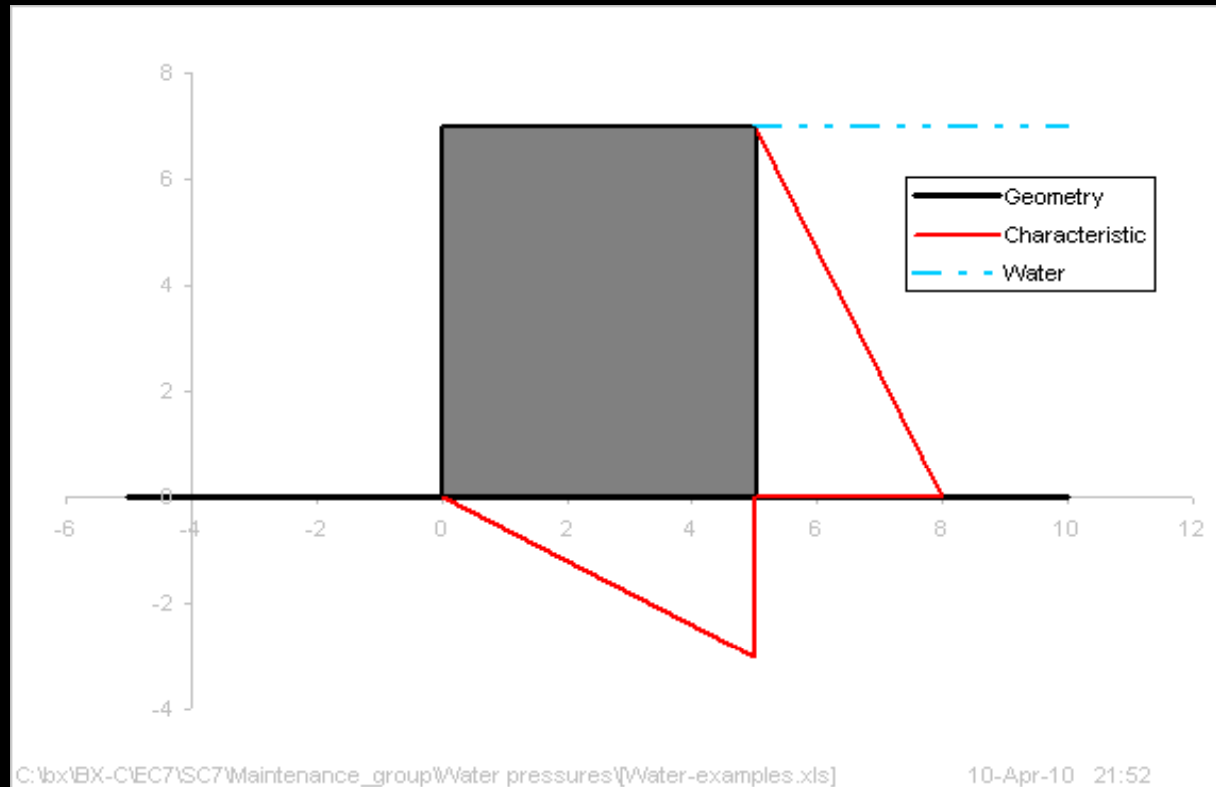

- Which limit states are relevant?
  - Sliding – GEO
  - Bearing capacity – GEO
  - Internal strength – STR
  - EQU? Toppling?

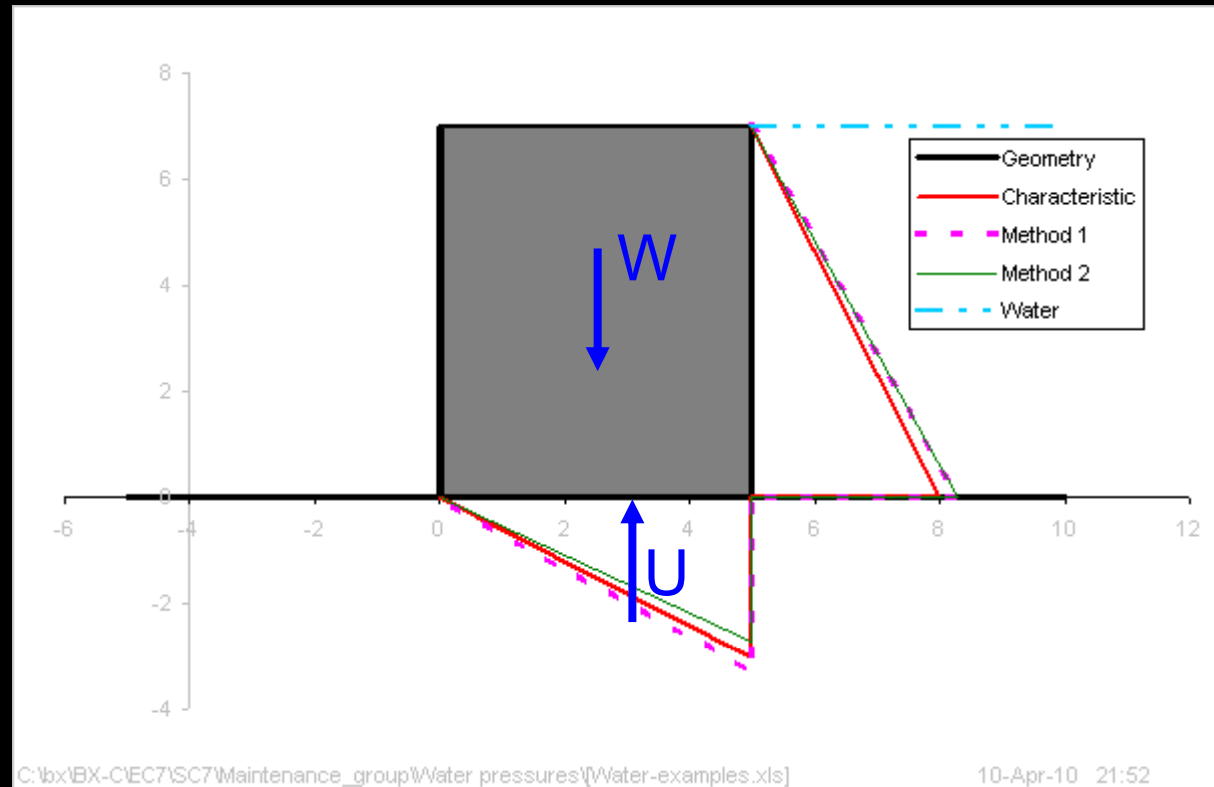

- Do we factor water pressure?
- “Single source”? Same factors on horizontal and vertical at a point?
- Effect of factoring buoyant weight?  $\gamma_{stb}(W_k - U_k)$

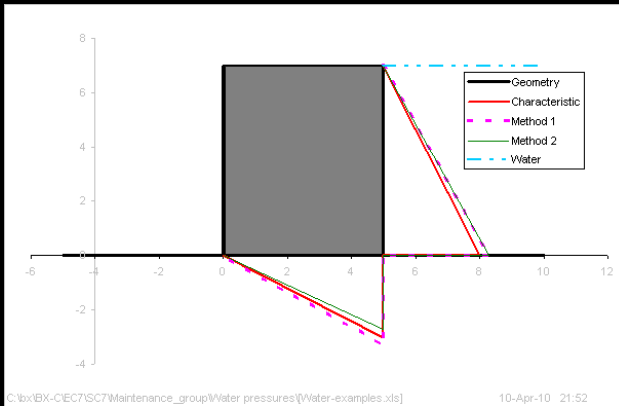

Example 1: consequences for sliding

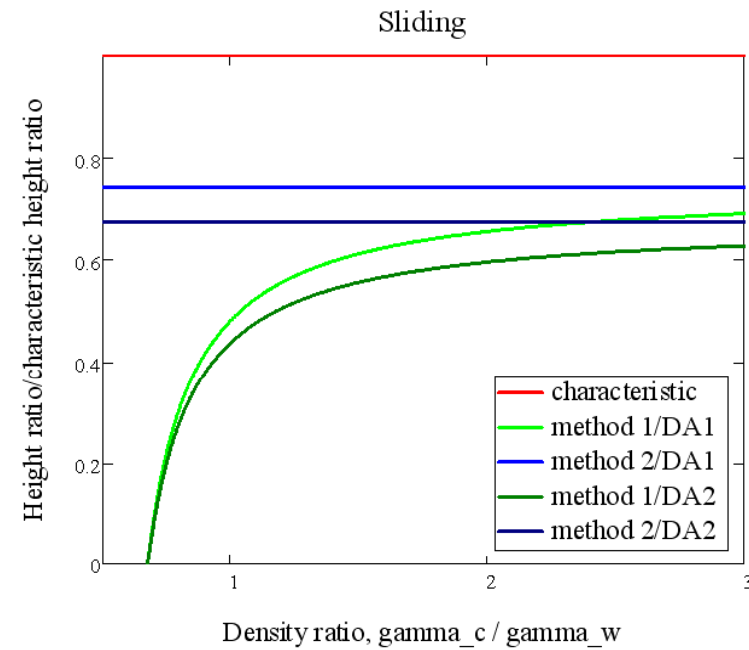
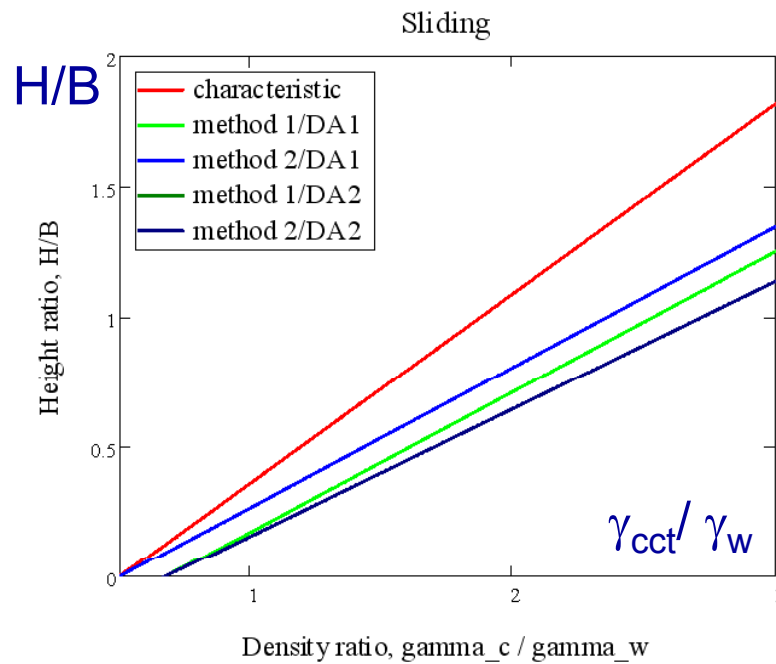

Observation: as the density of the block reduces towards and below that of water, so the acceptable height reduces dramatically



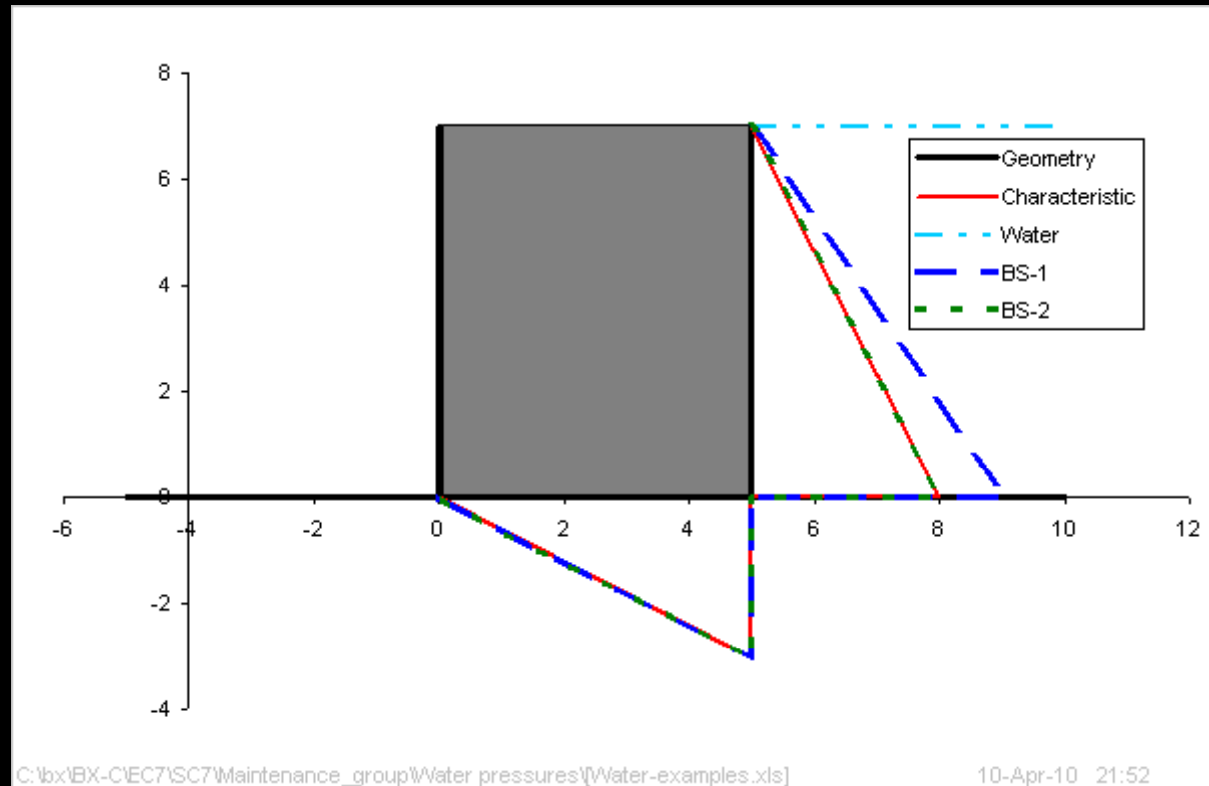

- Two combinations (DA1)
- Same water pressures for all calculations.
- Not “single source” (in any of the plots)
- For all methods, results very dependent on factor values, including material or resistance factors for BC.

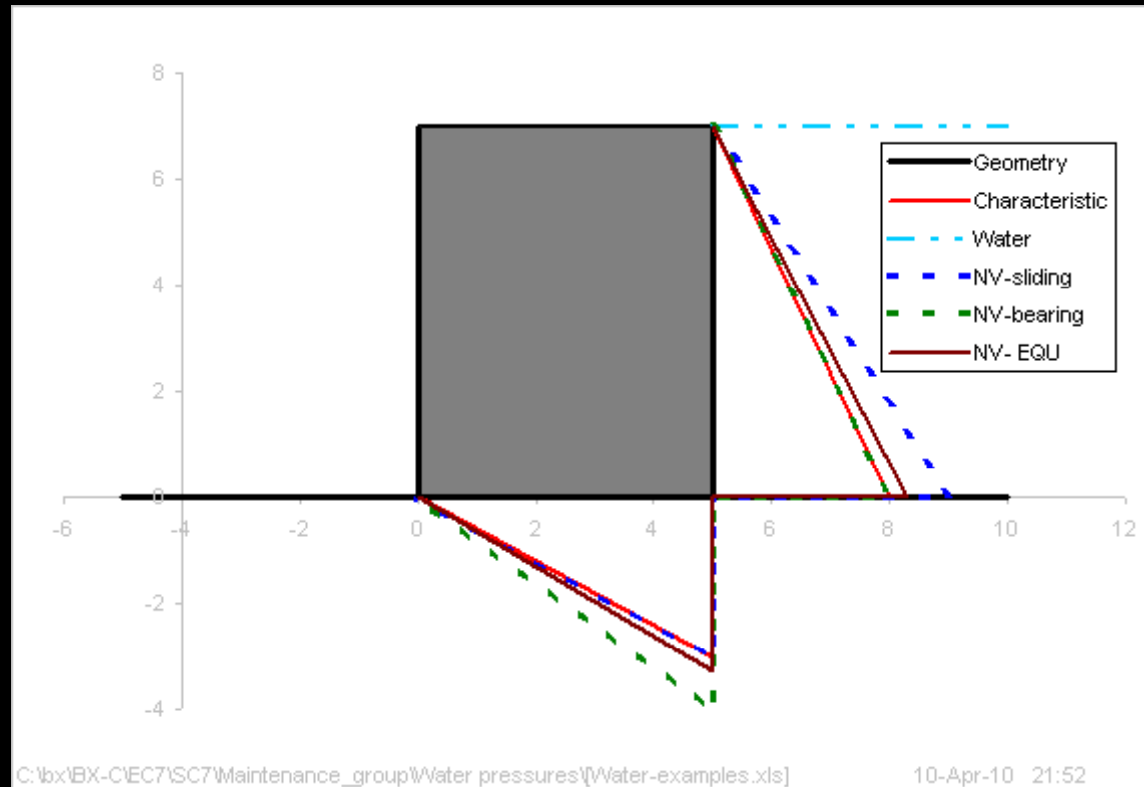

- Different water pressures for each limit state?
- No water pressures less than characteristic
- Not simply using the most critical?

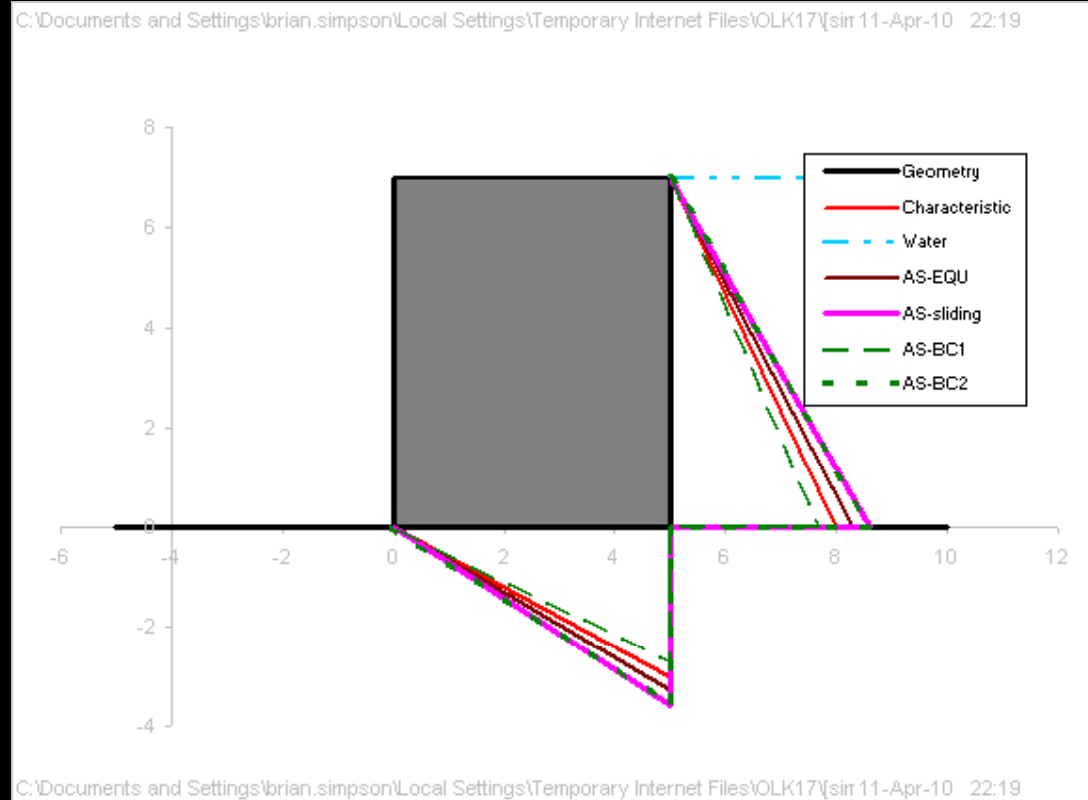

- $\gamma_G$  lower for water pressure?
- Water pressure less than characteristic considered
- This one is “single source”.

## Example 3

- How many piles?
- How to compute design BM?

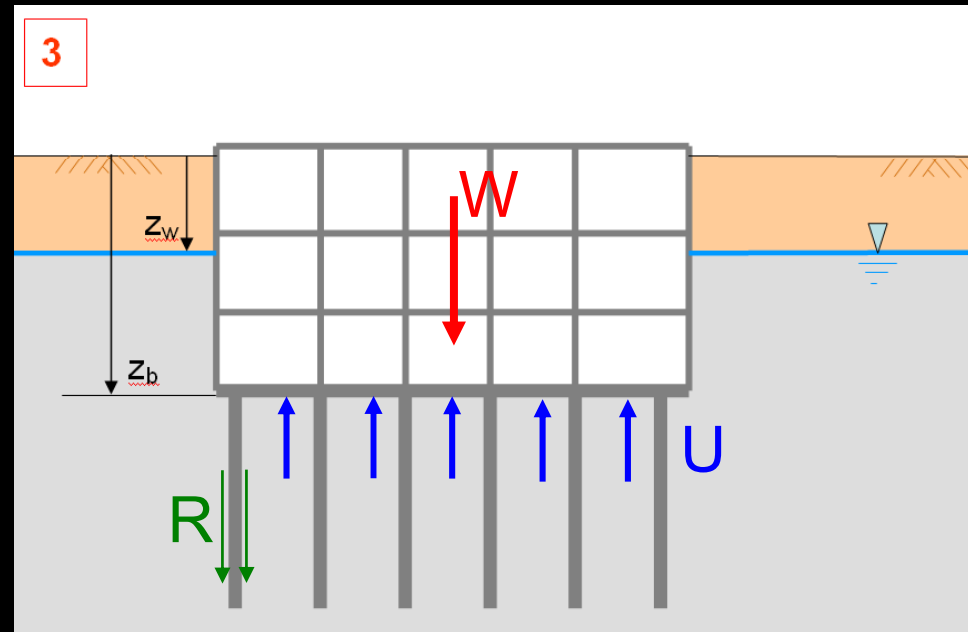

An urban deep basement. The principal concern addressed here is holding the basement down against the upward pressure of the water beneath it, using bored piles in tension.

The geology consists of gravel over clay with the observed water level at the surface of the clay. Other future construction in the area might, in theory, cause the water table to rise, but this is thought to be unlikely. However, calculations suggest that at the worst the rise could be 1.0 to 1.5m. No holding-down force is provided by the ground in shear on the walls. There is no drainage beneath the basement.

The plan area of the basement is  $A$ , and its characteristic weight is  $W_k$  (a permanent action, uniformly distributed). The characteristic *geotechnical* resistance of each pile in tension is  $R_{t,g}$  and there is no interaction between piles or group effect to be considered. No load testing will be carried out for the piles.

$u_b$  is the water pressure at depth  $z_b$ . The weight density of water is  $\gamma_w$ .

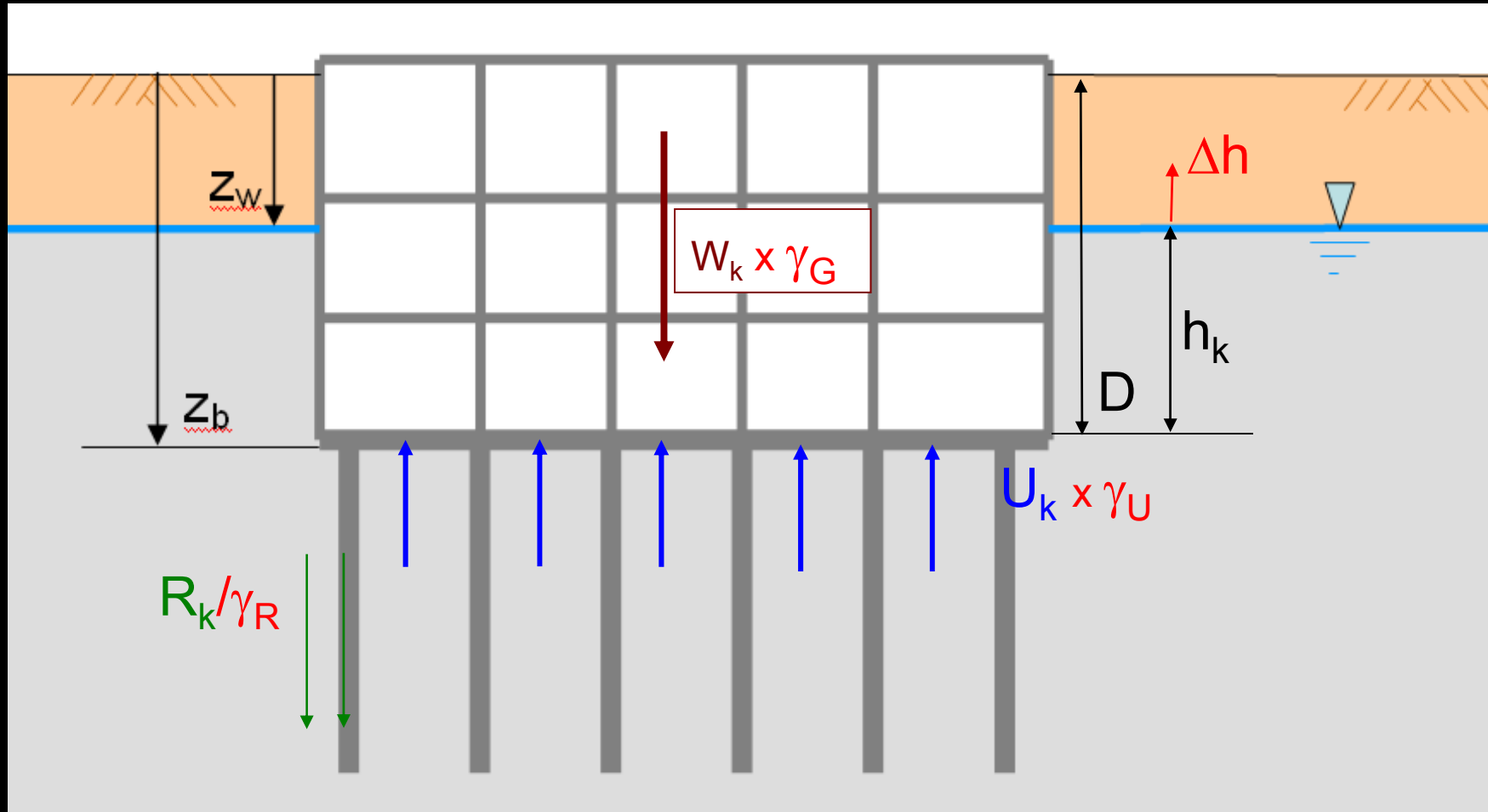

$$\gamma_G = \gamma_{F,inf} \text{ or } \gamma_{F,stb}$$

$$\gamma_U = \gamma_{F,sup} \text{ or } \gamma_{dst}$$

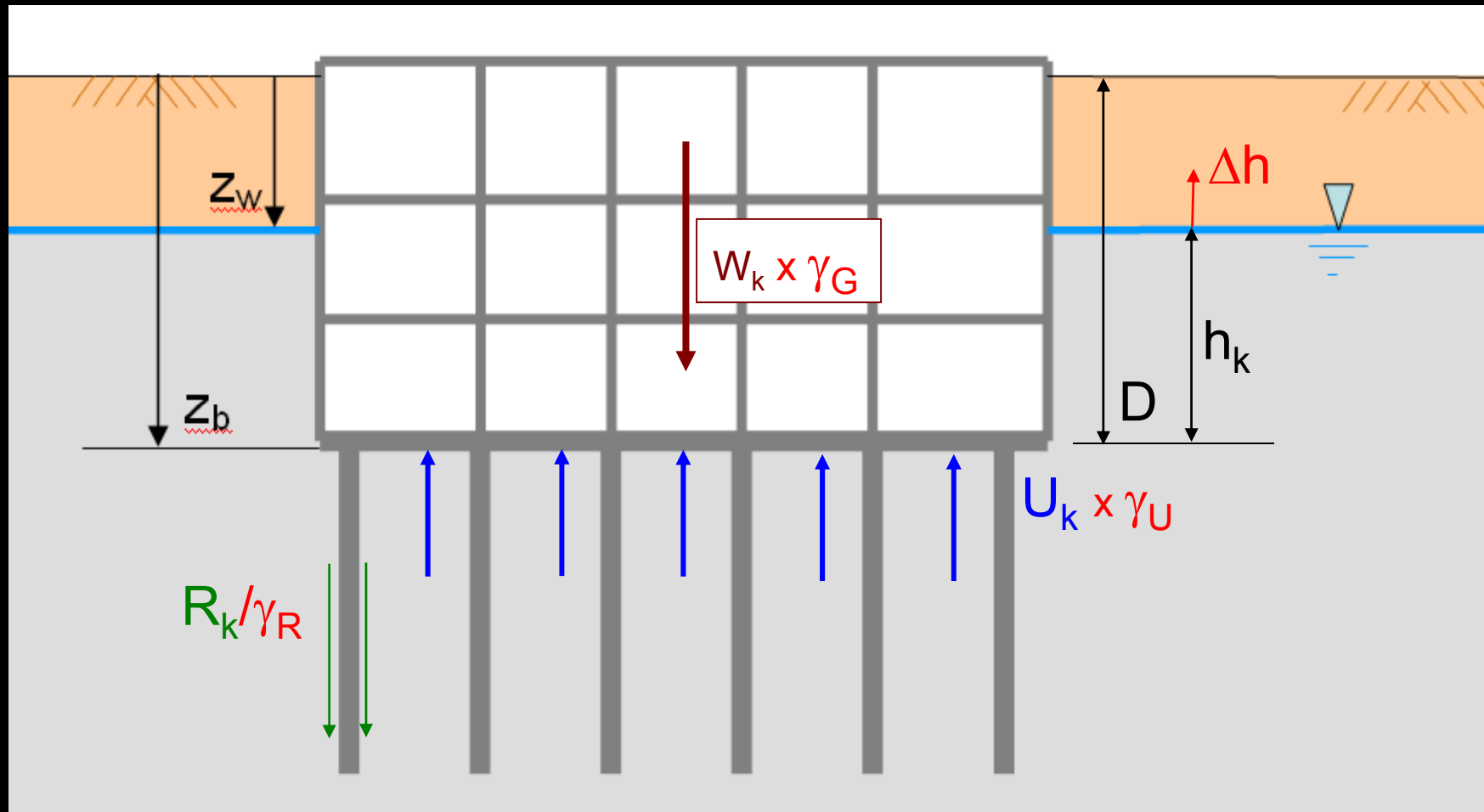

- Water head ratio  $h_k/D$ 
  - How much water pressure

- Weight ratio  $W_k / (\text{vol} \times \gamma_w)$ 
  - How heavy is the building

- Anchorage ratio  $nR_k / W_k$ 
  - How much anchorage

## Example 3 – Characteristic situation

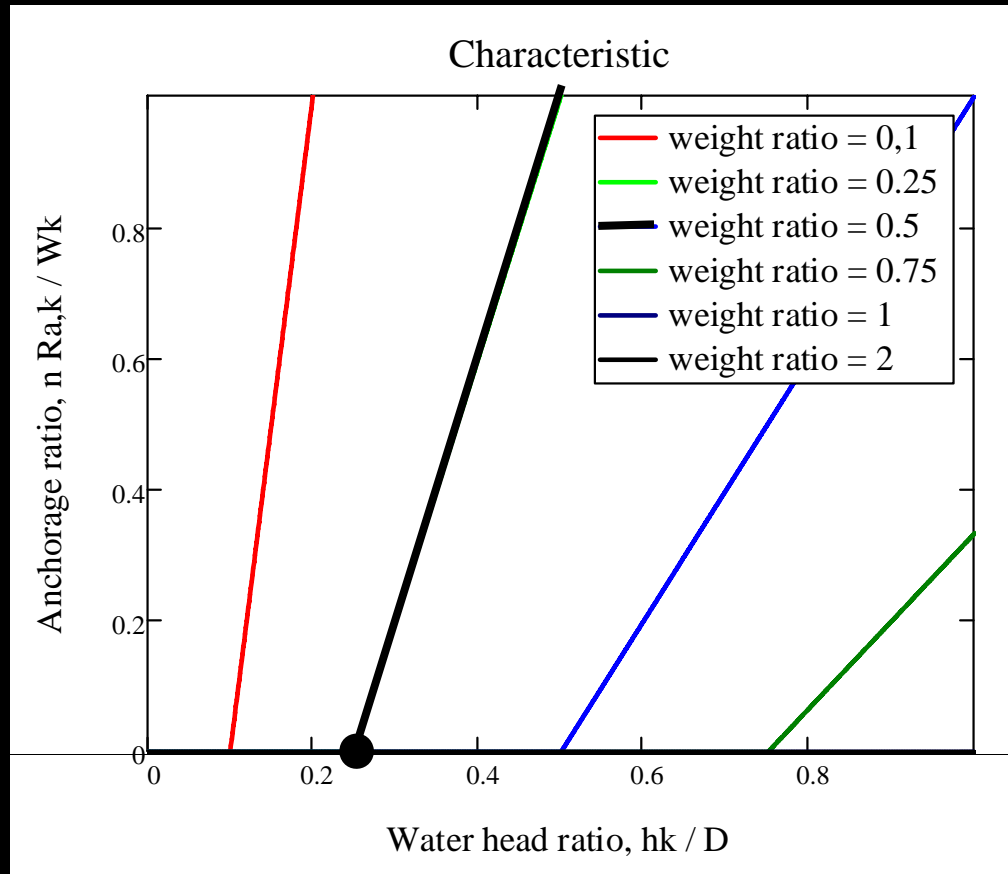

- Anchorage ratio  
 $n R_k / W_k$ 
  - How much anchorage
- Water head ratio  
 $h_k / D$ 
  - How much water pressure
- Weight ratio  
 $W_k / (\text{vol} \times \gamma_w)$ 
  - How heavy is the building

# Weight ratio 0.25. $\Delta h=0$ .

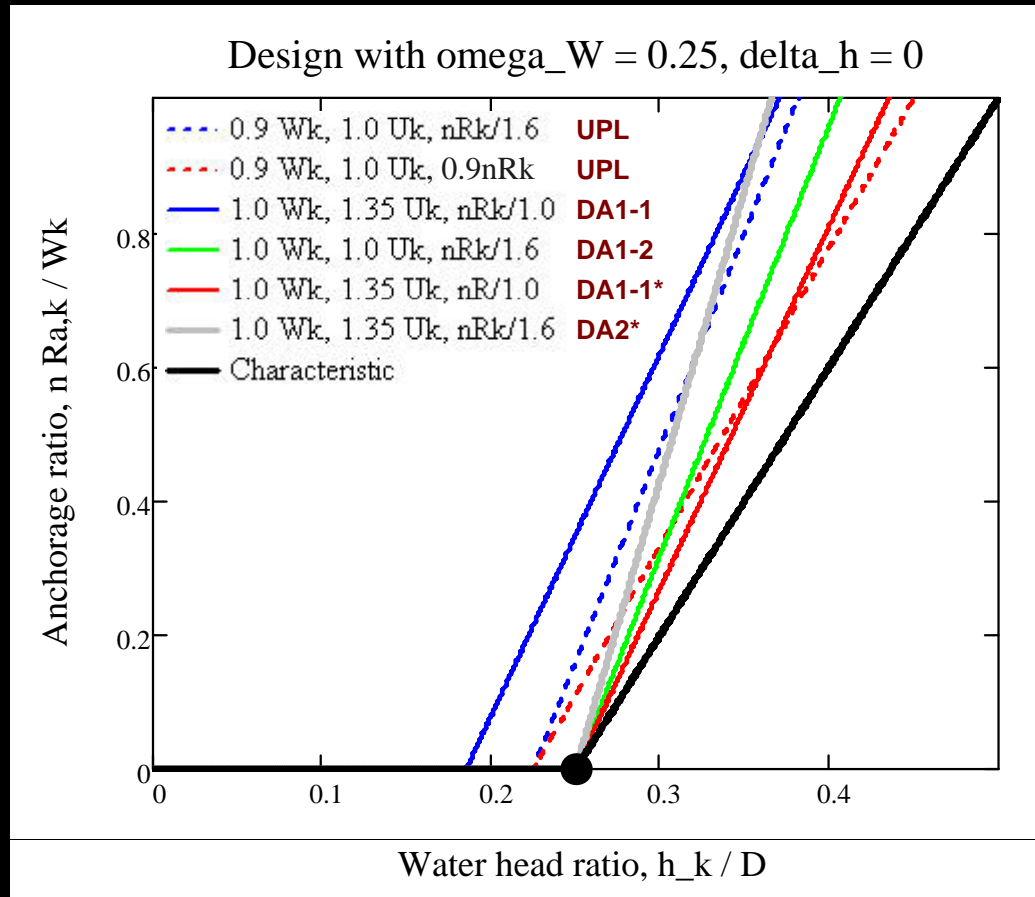

- For high water heads, all methods give some safety.
  - How much is needed?
- Near the balance point, safety is only provided by increasing the water pressure.



Weight ratio = 0.25.  $\Delta h = 0.1$

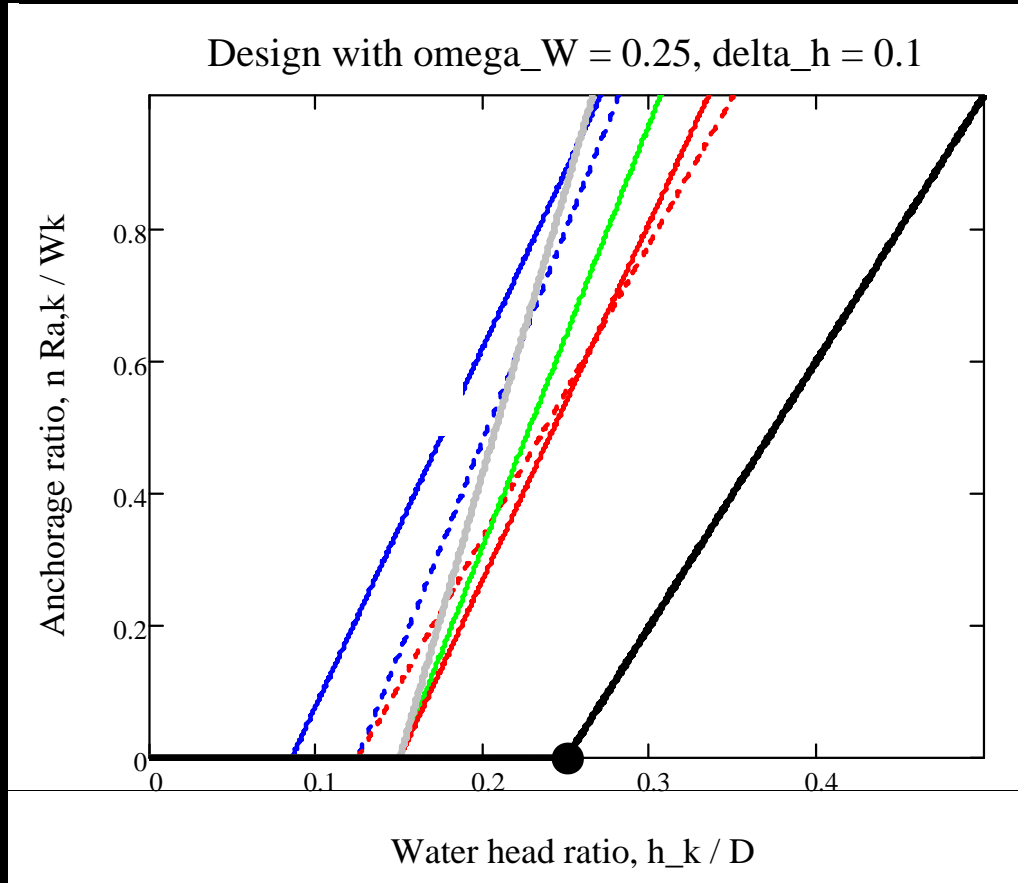

- Increasing the head by  $\Delta h$  provides a safety margin.
- But would this be used in addition to other safety factors?

--- 0.9 $W_k$ , 1.0 $U_k$ , $nR_k/1.6$	UPL
--- 0.9 $W_k$ , 1.0 $U_k$ , $0.9nR_k$	UPL
— 1.0 $W_k$ , 1.35 $U_k$ , $nR_k/1.0$	DA1-1
— 1.0 $W_k$ , 1.0 $U_k$ , $nR_k/1.6$	DA1-2
— 1.0 $W_k$ , 1.35 $U_k$ , $nR/1.0$	DA1-1*
— 1.0 $W_k$ , 1.35 $U_k$ , $nR_k/1.6$	DA2*
— Characteristic	

Weight ratio = 0.75 (heavy building).  $\Delta h=0.1$ .

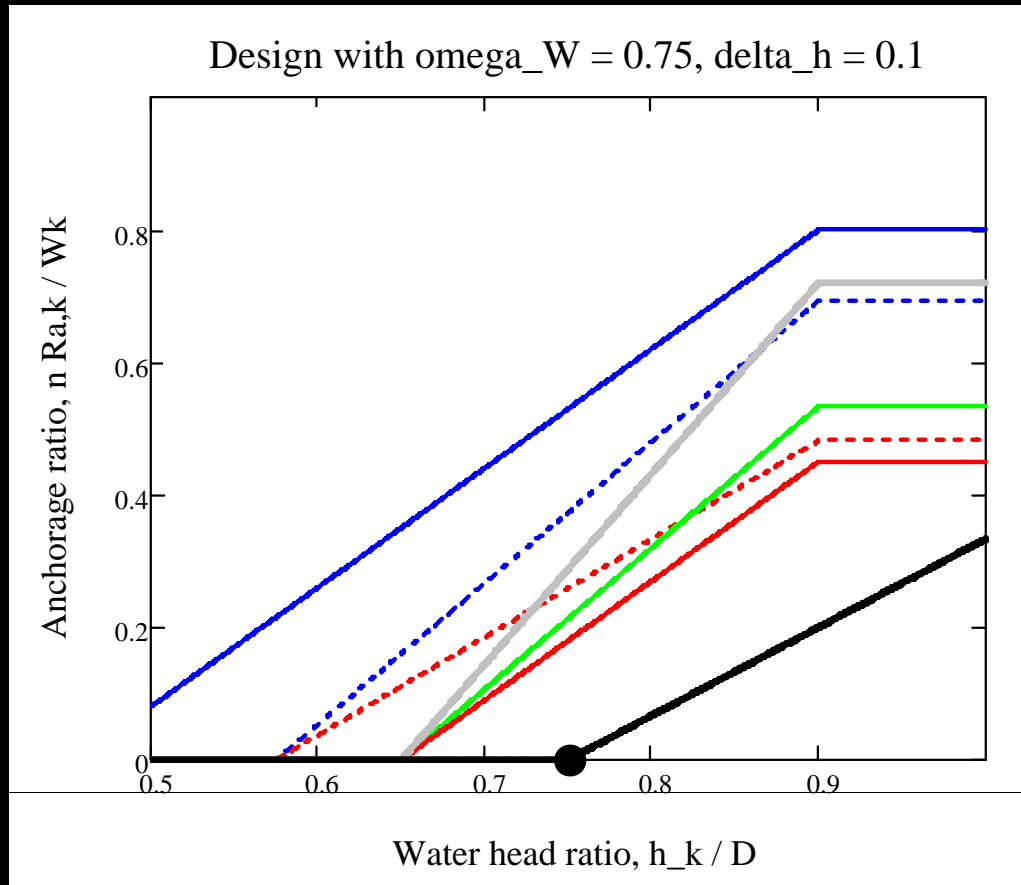

- Similar pattern.
- Factoring water pressures starting to dominate effect of  $\Delta h$ .

0.9 Wk, 1.0 Uk, nRk/1.6	UPL
0.9 Wk, 1.0 Uk, 0.9nRk	UPL
1.0 Wk, 1.35 Uk, nRk/1.0	DA1-1
1.0 Wk, 1.0 Uk, nRk/1.6	DA1-2
1.0 Wk, 1.35 Uk, nR/1.0	DA1-1*
1.0 Wk, 1.35 Uk, nRk/1.6	DA2*
Characteristic	

Weight ratio = 0.75 - *my preference*

$\Delta h = 0.1$  or  $\gamma^*$

, 0.9nRk

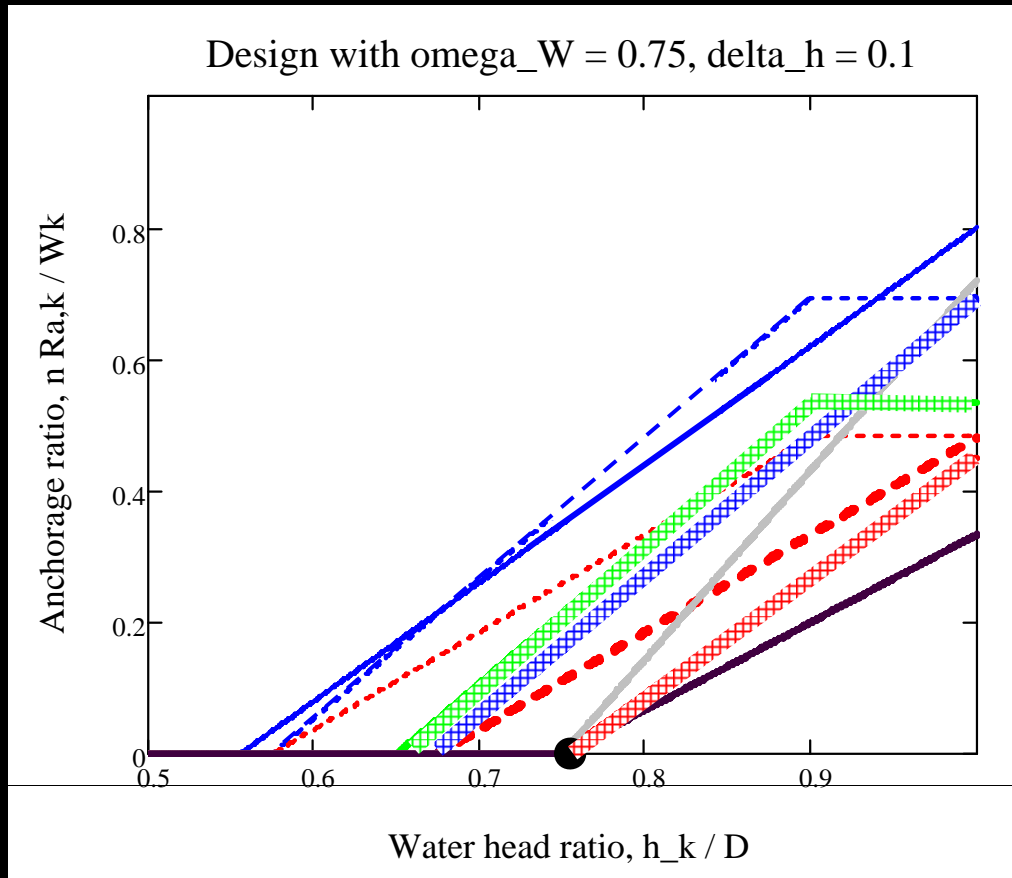

- DA1-1\* becomes critical for bending moment.

--- 0.9 Wk, 1.0 Uk, nRk/1.6	UPL
--- 0.9 Wk, 1.0 Uk, 0.9nRk	UPL
--- 0.9 Wk, 1.0 Uk, nRk/1.6, no dh	UPL
--- 0.9 Wk, 1.0 Uk, no dh	UPL
--- 1.0 Wk, 1.35 Uk, nRk/1.0, no dh	DA1-1
--- 1.0 Wk, 1.0 Uk, nRk/1.6	DA1-2
--- 1.0 Wk, 1.35 Uk, nRk/1.0, no dh	DA1-1*
--- 1.0 Wk, 1.35 Uk, nRk/1.6, no dh	DA2*
--- Characteristic	

## Some thoughts

- Avoid factoring water pressures – always??
- Margins better than factors.
- Perhaps factor *differential* water pressure.
- Single source?
- Can we retain physical reason?
- Apply a lot of common sense.